

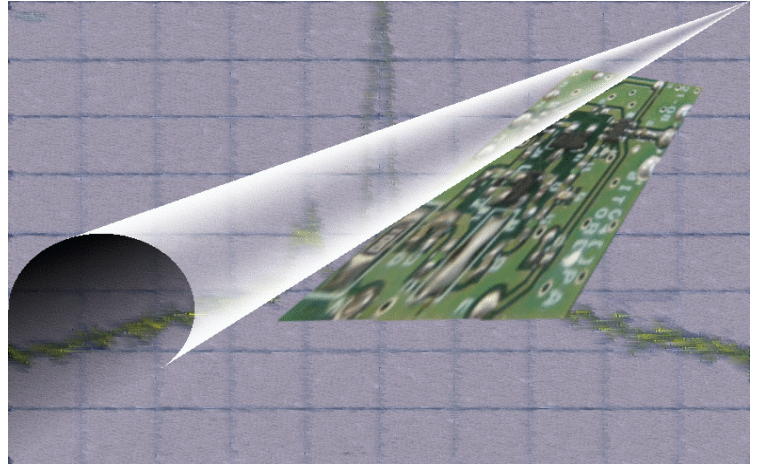

Your best partner
for embedded
RF design



BITxxPA

Power Amplifier Module

Very low cost power amplifier module designed for band 433 or 868 MHz applications in a very small package (15,3x15,3 mm)

Highly Integrated solution

The **BITxxPA** modules is a very small complete and compact RF Power amplifier.

BITxxPA is the ideal companion of BITxxRT and BITxxRM in the 433 and 868 MHz version.

The product is available for RF applications in the 433, 868 MHz unlicensed ISM(Industrial, Scientific and Medical) and SRD (Short Range Device) frequency bands.

BITxxPA is ideal solution for home and building automation, control system, sensor networks, etc.

Module is SMT assembled.

Lead-free "green package."

With only 15,3x15,3 **mm footprint** the modules provide a real **cost-effective** wireless solution.

Matching Impedance is 50 ohm both in input, as in output

No additional components are needed.



Should you need any other information or customization don't hesitate to call us.

Features

- High Gain, up to 20 dB @ 433 and 10 db @ 868 Mhz
- Low insertion loss in Rx Mode (< 1dB)
- Small size (15,3x15,3 mm)
- Low current consumption
- 2.3 - 12 V Power Supply
- -40°C to +85°C operating temperature
- Custom solutions on request

Pin-Out

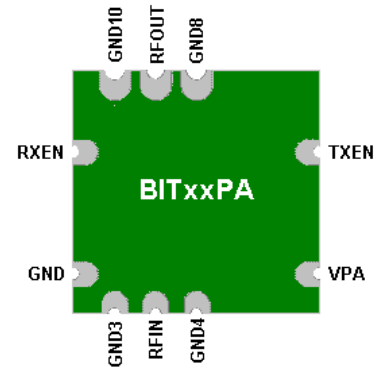

Applications

- Alarm and security systems
- Home and building automation
- Wireless sensor networks
- Telemetry Station
- Wireless audio
- OEM equipment

Typical Application

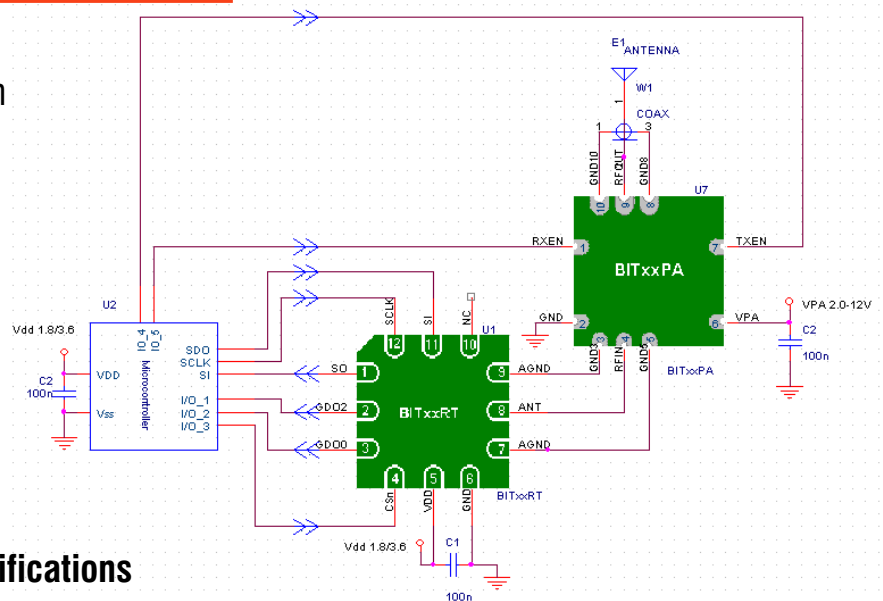

Operating Conditions and Specifications

Parameter	Min.	Typ.	Max.	Units	Remarks
RF Frequency Range	432.0	434	436.0	MHz	BIT04PA
	865.0	869	873.0	MHz	BIT08PA
Operation temperature	-40		+85	°C	
Supply voltage	2.5		12	V	Pin VPA
	2.5		7	V	Pin TXEN , RXEN
Current Consumption		0.1		uA	TXEN & RXEN @ 0V (stand-by mode)
		25		uA	TXEN @ 0V, RXEN @ 3V (RX Mode)
		28		mA	TXEN @ 3V, RXEN @ 0V, VPA @ 3V
		38		mA	TXEN @ 3V, RXEN @ 0V, VPA @ 5V
		45		mA	TXEN @ 3V, RXEN @ 0V, VPA @ 7.2V
		51		mA	TXEN @ 3V, RXEN @ 0V, VPA @ 12V
Input power			10	dbm	
Max Output Power		14		dbm	VPA @3.3V
		18		dbm	VPA @ 12V
Input Impedance		50		ohm	
Output Impedance		50		ohm	

BITxxPA Power Amplifier Module



Bit is Italian Technology S.r.l.
Via Settembrini, 29 - 20020 Lainate (MI)
Tel.: (+39) 02 30465311, fax: (+39) 02 30465358
<http://www.bit.it/> info@bit.it



<http://www.kevin.it/>

info@kevin.it